



AlZin Customer Benefits
Aug.201th, 2009
Dr. Wolfgang Glitscher
HEN N.V. Product application group

Interoffice Memorandum

AlZin customer benefits

Aug.2011th, 2009

Dr. Wolfgang Glitscher

HEN N.V. Product application group

- 1. The lab aspect.** The cost for ICP analysis for a big steel group was 25€ per sample in the year 2002. Now 7 years later the cost is over 30€ per ICP test. As standard customer had taken 2 samples per day till AlZin was introduced. Today still one sample per week is taken. 9 samples per week are being saved today representing 270€ per week, 1100€ per month. A 4 weeks period consumes 2 AlZin sensors corresponding to 930€ cost. No doubt, at this time AlZin is already somewhat less expensive than the lab. Customers tell us that it is their intention to even replace the laboratory in future completely. The lab uses total Al, Fe and temperature to calculate the effective aluminium concentration; AlZin reads direct effective aluminium without being effected by dross. The new AlZinlog-E software comprises as well an iron calculation model so that even occasional Fe-lab checks may be superfluous or at least be reduced to a minimum.
- 2. The precision and the calibration aspect.** AlZin does not need calibration. The electrochemical sensor nature and its type of cell impregnation allocate all calibration issue to the lab whenever a comparison AlZin to lab is done. AlZin itself cannot deviate but sets the standard. AlZin measures the effective aluminium on-line. As an example Arcelor produce today a certain grade with a specification of just +/-20ppm Al (!!!) at a level of 0.130%Al. This would be impossible without AlZin. Due to substantial drift issues Arcelor do not trust spectrometer analysis but use ICP (inductively coupled plasma). Most galvanizers frankly agree to frequent lab problems in their plant.
- 3. Dross formation.** Dross formation in zinc coating cannot be avoided but minimized. Dross, as bottom or top dross, is an intermetallic compound and precipitated in its various forms as FeAlZn and FeAl. Dross is mostly either raked from the surface, but as it deposits as well on immersed sink and guide rolls, the rolls have to be taken out and maintained in regular intervals. Thus the first aspect is to minimize loss of aluminium and zinc to dross, but even more important is to prolong the service intervals of rolls. An extra roll change and associated production loss accounts for about 50.000Euro additional cost.

Figure 1

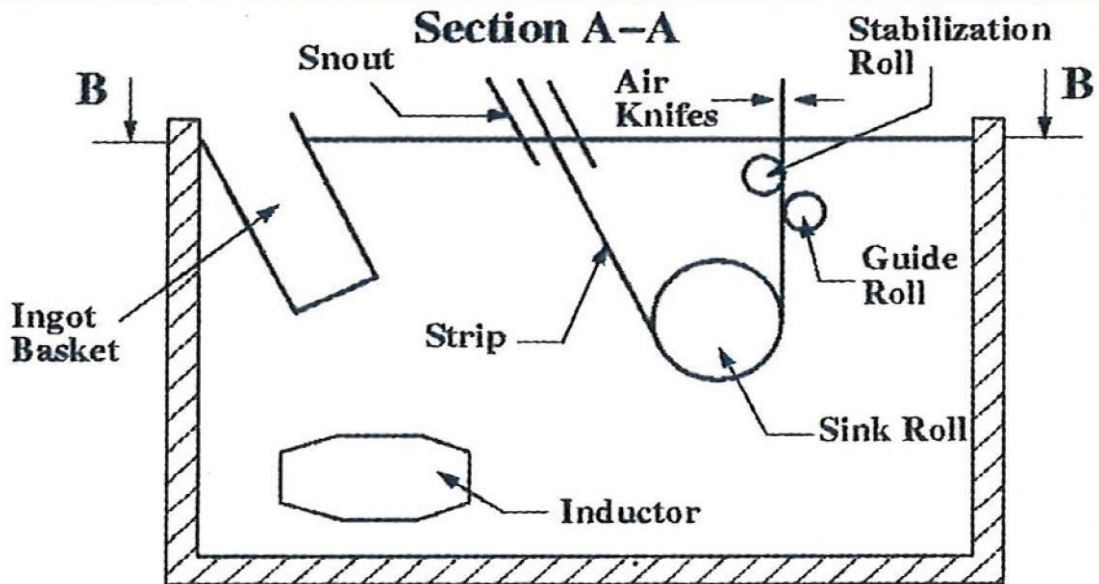

4. **The aluminium loss aspect.** In his paper from August 2006, Iron&Steel Technology Frank E. Goodwin from the International Lead Zinc Research Organization (ILZRO) calculates the aluminium loss alone due to non optimized metallurgy (addition of alloyed zinc ingots) and thus fluctuating bath compositions (remark: correct in downstream figure the precipitated Al to (% x 0.001).

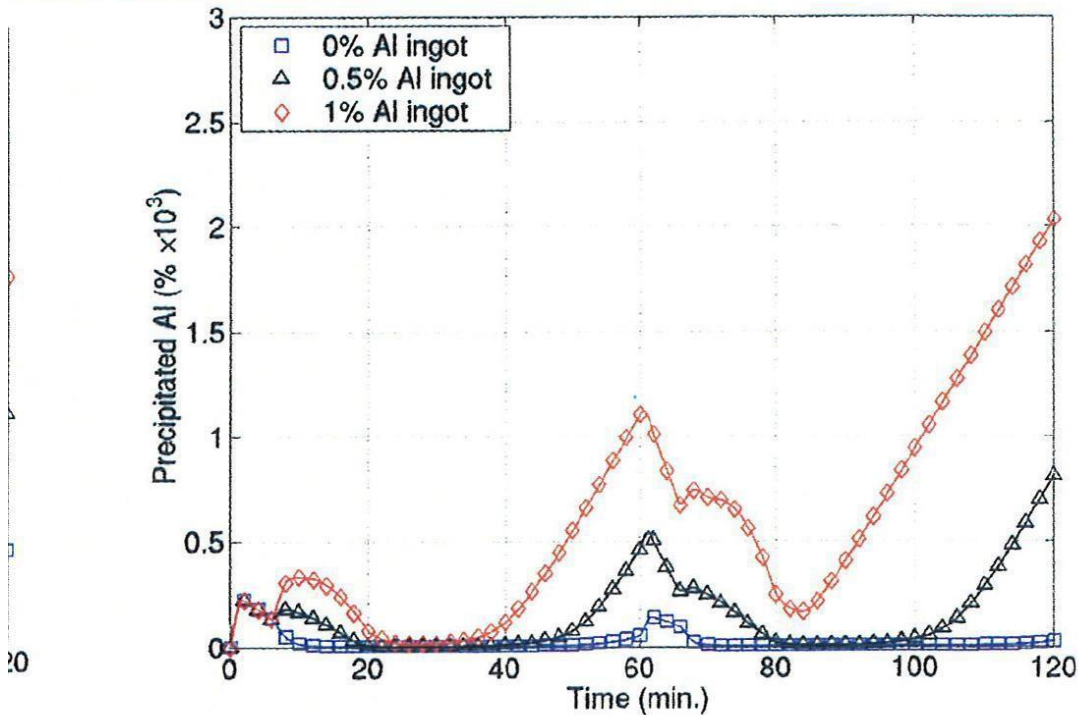

This means whenever a higher alloyed zinc ingot is used due to poor on-line control, the result is an unnecessary high loss in dissolved aluminium (lost to dross). The calculation for a 400t zinc pot shows a extra loss of 2kg Al/h = 3perEuro/h. Throughout the service life of an AlZin sensor of 2 weeks this loss amounts to a cost of 1000Euro, more than double the cost of AlZin.

5. The 'out of control' aspect. A 50t/h coating rate of steel strip means a value creation of 50.000Euro per hour (if we assume a price of 1000Euro per t of galvanized strip). Calculating 2 weeks of service life for the AlZin sensors (1000 Euro) and associated cost for the plant of 12.500Euro as one-time investment per line, AlZin cost is absolutely negligible. .

6. The transition aspect GA-GI-GA

When going from galvannealing to galvanizing, on-line aluminium control is a must, as aluminium changes are dynamic, and the laboratory cannot trace changes in time. A lab delay is not just risky, the certification of a certain production lot and a coil in terms of aluminium content of the coating layer is critical.

